

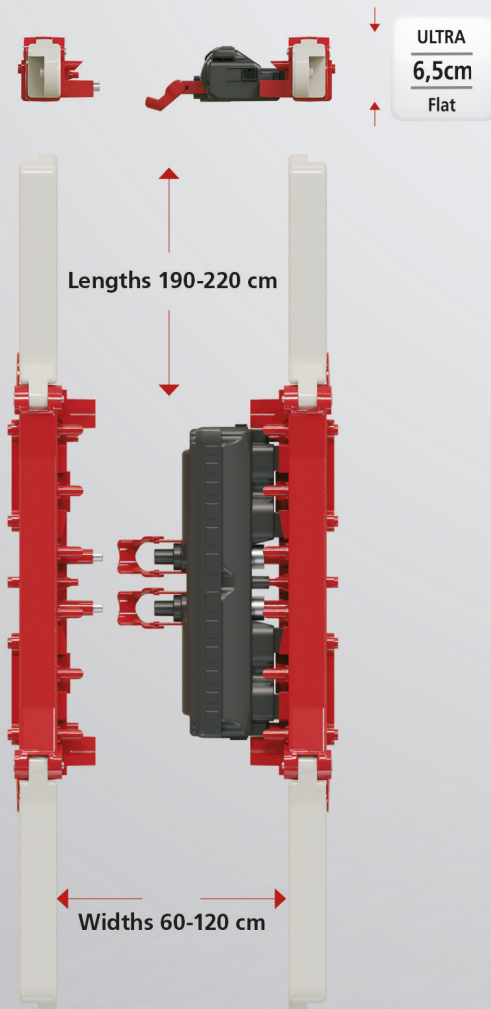

Safe downward function without traction for the back and foot area.



eMotion 2M DS
Drive System Technology



ACTUATORS



www.octo-actuators.de

**INVISIBLE
INTEGRATED**
DRIVE SYSTEM TECHNOLOGY

eMOTION 2M *To Go*

eMotion 2M

The eMotion 2M drive technology is based on a twin-motor OCTO drive system for adjusting the back and foot areas and can be fully integrated into a sofa / lounger.

In all 4 zones allow hassle-free adjustment of each comfortable reclining, sitting and relaxing position.

The system components within the structure offer appropriate locking options of moulded and comfort foam so that an elegant external shape is ensured during the operation of back zone. All popular foam types (PU, Visco) and pocket spring technologies can be used.

The system does not require any metal fittings and offers more design freedom with a system height of just 65 mm for completely invisible integration within the sofa / lounger.

eMotion 2M "Version TDS Plus"

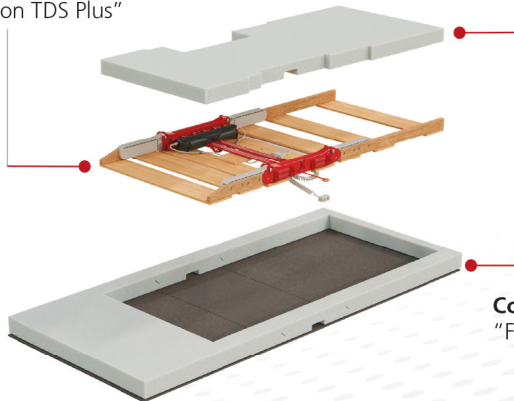

Cookie
"Freeform foam body"

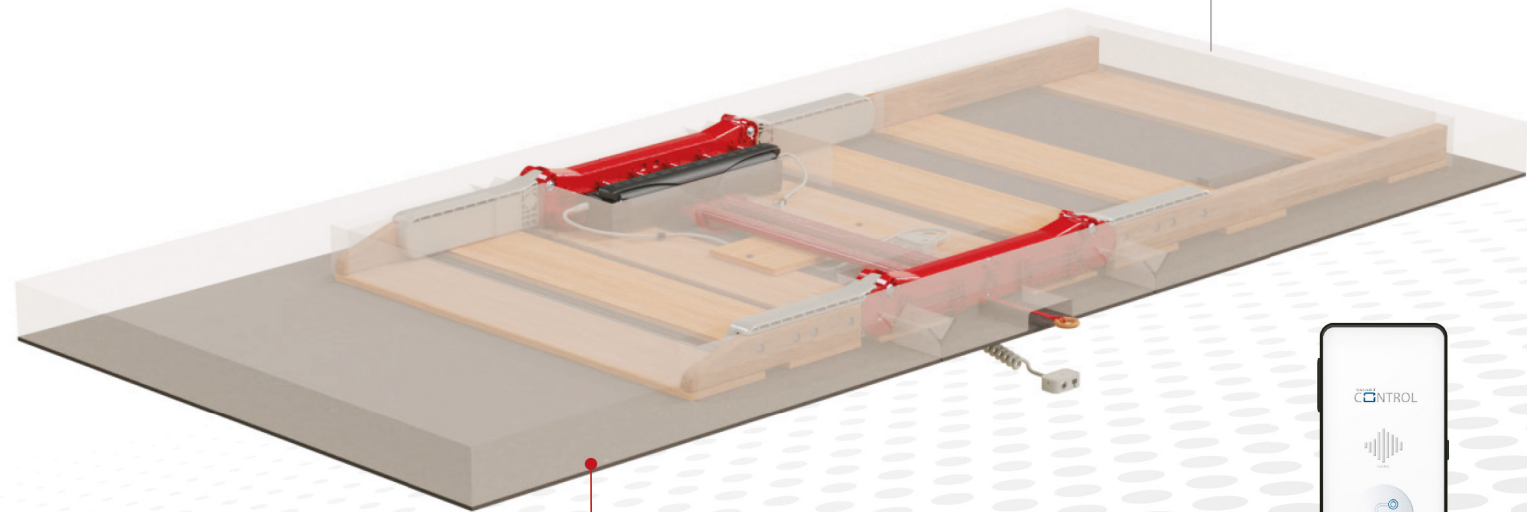

Cookie incl.
Drive technology eMotion 2M TDS+



eMotion 2M Drive System
Invisible integrated



Smart APP Control
"optional"